



PLEASE READ

This manual is from the manufacturer—**GoTo Connect may not support some features discussed in this document.**

Please see our online documentation for a complete list of supported features.

Thanks for choosing us!

8028 SIP Doorphone FW Version 2.7.4

Installation & Configuration

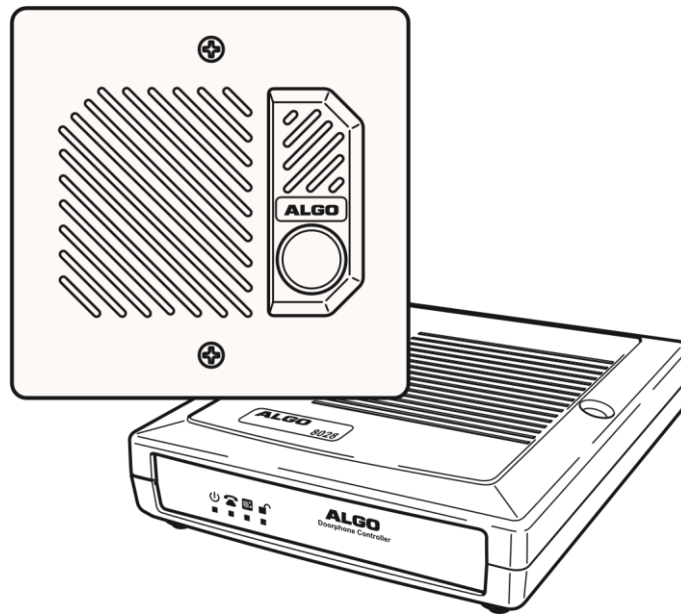

Order Codes

8028 SIP Doorphone

Table of Contents

IMPORTANT SAFETY INFORMATION	5
ABOUT THE ALGO 8028 SIP DOORPHONE	6
GETTING STARTED - QUICK INSTALL & TEST	7
APPLICATIONS	8
TYPICAL APPLICATIONS FOR AUXILIARY INPUTS AND OUTPUTS	8
<i>Cancel Ring When Door Opened</i>	<i>8</i>
<i>Trigger Door Bell from Door Station.....</i>	<i>8</i>
<i>Trigger Door Station from External Button/Event.....</i>	<i>8</i>
<i>Cancel Door Open Relay once Door Opened</i>	<i>8</i>
<i>Unlock Door Indefinitely until Canceled</i>	<i>9</i>
<i>Anti-Door Tamper</i>	<i>9</i>
<i>In-User and Ring.....</i>	<i>9</i>
INSTALLATION	10
DOOR STATION INSTALLATION	11
DOOR OR GATE CONTROL BASICS.....	12
DOOR RELEASE.....	12
<i>Fail Locked / Fail Secure Electric Strike.....</i>	<i>12</i>
<i>Fail Unlocked / Fail Safe Electric Strike.....</i>	<i>12</i>
<i>Power Supply.....</i>	<i>13</i>
PRE-WIRING INSTRUCTIONS	13
WIRING CONNECTIONS.....	14
AUXILIARY DRY CONTACT OUTPUTS	15
AUXILIARY DRY CONTACT INPUTS	15
RED LED INDICATORS.....	16
POWER	16
TELEPHONE.....	16
DOOR STATION.....	16
UNLOCK.....	16
WEB INTERFACE.....	17
WEB INTERFACE LOGIN	18
STATUS.....	18
BASIC SETTINGS TAB – SIP.....	19
SIP DOMAIN (PROXY SERVER).....	19
EXTENSION	19
AUTHENTICATION ID	19
AUTHENTICATION PASSWORD.....	20
DIALING EXTENSIONS.....	20
BASIC SETTINGS TAB - AUDIO	21
SPEAKER VOLUME.....	21

- MICROPHONE VOLUME..... 21
- RINGBACK TONE 21
- BASIC SETTINGS TAB – DOOR RELAY 22**
 - MOMENTARY OPEN CODE 22
 - DURATION 22
 - CANCEL IF DOOR OPENED 22
 - LATCH OPEN CODE..... 23
 - LATCH CLOSED CODE 23
 - DTMF DETECTION TYPE..... 23
 - DOOR UNLOCK TONE..... 23
 - ALLOW NETWORK CONTROL 23
- ADVANCED SETTINGS TAB - NETWORK 24**
 - PROTOCOL 24
 - VLAN MODE..... 24
 - VLAN ID 25
 - VLAN PRIORITY 25
 - DIFFERENTIATED SERVICES (6-BIT DSCP VALUE) 25
- ADVANCED SETTINGS TAB – ADMIN 26**
 - PASSWORD..... 26
 - CONFIRMATION 26
 - DEVICE NAME 26
 - INTRODUCTION SECTION ON STATUS PAGE 27
 - WEB INTERFACE SESSION TIMEOUT..... 27
 - LOG LEVEL..... 27
 - LOG SIZE 27
 - LOG METHOD 27
 - LOG SERVER 27
 - HARDWARE WATCHDOG 27
 - SNMP SUPPORT (v1 GET ONLY) 27
- ADVANCED SETTINGS TAB – TIME..... 28**
 - TIME ZONE..... 28
 - NTP TIME SERVER 28
- ADVANCED SETTINGS TAB – PROVISIONING 29**
 - MD5 CHECKSUM..... 30
 - GENERATING A GENERIC CONFIGURATION FILE 30
 - GENERATING A SPECIFIC CONFIGURATION FILE..... 31
- ADVANCED SETTINGS TAB – CALL 32**
 - ANSWER INBOUND CALL..... 32
 - ANSWER TONE 32
 - OUTBOUND RING LIMIT 32
 - CANCEL IF DOOR OPENED 33
 - ALLOW CALL BUTTON TO END OUTBOUND CALL..... 33
 - MAXIMUM CALL DURATION..... 33

- ADVANCED SETTINGS TAB – AUXILIARY I/O 34
 - CONTROLLER OUTPUT 34
 - DOOR STATION OUTPUT..... 34
 - IN-USE DEFINITION 35
 - CONTROLLER INPUT 35
 - DOOR STATION INPUT..... 35
- ADVANCED SETTINGS TAB – SECURITY 36
 - MAX DOOR OPEN..... 36
 - DOOR OPEN ALARM..... 36
 - DOOR STATION DISCONNECTED 36
- ADVANCED SETTINGS TAB – ADVANCED SIP 37
 - OUTBOUND PROXY 37
 - STUN SERVER 37
 - REGISTER/SUBSCRIBE PERIOD (SECONDS) 37
 - KEEP-ALIVE METHOD 37
 - SERVER REDUNDANCY FEATURE 38
 - BACKUP SERVER #1..... 38
 - BACKUP SERVER #2..... 38
 - POLLING INTERVALS (SECONDS)..... 38
 - POLL ACTIVE SERVER 38
 - AUTOMATIC FAILBACK 38
 - POLLING METHOD 38
- SYSTEM TAB - MAINTENANCE..... 39
 - DOWNLOAD CONFIGURATION FILE..... 39
 - RESTORE CONFIGURATION FILE 39
 - RESTORE CONFIGURATION TO DEFAULTS 39
 - REBOOT THE DEVICE 39
 - METHOD..... 39
 - FIRMWARE IMAGE 40
 - MD5 CHECKSUM..... 40
- SYSTEM TAB - NETWORK LOGGING 40
- SPECIFICATIONS..... 41
- FCC COMPLIANCE STATEMENT 44

Important Safety Information

The 8028 SIP Doorphone is designed and tested to comply with EN 60950-1:2006 safety requirements.



INSTALLATION

When the Doorphone Controller is connected to wiring that exits the building, there is potential risk of lightning induced electrical surges or high voltages from fault conditions. To reduce risk, outdoor wiring should be protected by Earth grounded conduit whenever possible.

If outdoor wiring will be connected to the Doorphone Controller then the power supply provided with the Doorphone Controller must first be connected to a properly Earth grounded mains supply. Under no circumstances can the Doorphone Controller be disconnected from Earth ground while connected to outdoor wiring.



EMERGENCY COMMUNICATION

If used in an emergency communication application, the 8028 SIP Doorphone should be routinely tested. SNMP supervision is recommended for assurance of proper operation.

About the Algo 8028 SIP Doorphone

Ideal for secure business entrances, emergency intercom, and residential gates, Algo's 8028 SIP Doorphone provides hands-free intercom capability, entrance security with door unlock control, rugged weatherproof design, and superior audio performance.

Fully compatible with SIP industry standards, the 8028 SIP Doorphone will work with most hosted or enterprise SIP-based servers supporting third-party SIP endpoints.

The 8028 Doorphone includes a Control Unit, Door Station, and Power Supply. The Control Unit and Door Station can be connected with a single twisted pair wire up to 1,000 feet (300 m) with the Door Station located outdoors and the Control Unit in a dry indoor location.

What is Included

- 8028 Digital Door Station & Controller
- Power Supply
- Stainless Steel & Brass Faceplates
- 6ft (2m) Network Cable

What is not Included

- Physical Door Sensor
- Door Strike
- Door Strike Power Supply
- This Installation Guide (www.algosolutions.com/8028/guide)

Getting Started - Quick Install & Test



This guide provides important safety information which should be read thoroughly before permanently installing the device.

1. Connect the power supply to the Power Jack of the Doorphone Controller and plug into an available AC outlet.
2. Flush or surface-mount the Digital Door Station at desired location and connect a twisted telephone wire pair between the "CTRL" terminals of the Door Station and the center pair (red and green) of the supplied Telephone Wiring Jack. Polarity is not important.
3. Using the short six conductor modular cable, connect the Telephone Wiring Jack to the Door Station Jack of the Doorphone Controller.
4. Using an Ethernet cable, connect the Ethernet Jack of the Doorphone Controller to your LAN.
5. Press the call button on the Door Station. A recorded voice will speak the IP Address of the device. (Once the SIP Server field is populated in the 8028 web interface (Step 7), the call button will contact the preconfigured extension when pressed.) The IP address may also be discovered by downloading the Algo locator tool to find Algo devices on your network: www.algosolutions.com/locator
6. Access the 8028 web interface by entering the IP address into a browser (Chrome, IE, Firefox, etc.) and login using the default password **algo**.
7. Use the Web Interface to enter the SIP Proxy Server address under the **BASIC SETTINGS > SIP** tab.
8. Enter the SIP Extension, Authentication ID, and Password. Also, enter the target Dialing Extension that the Door Station will call.

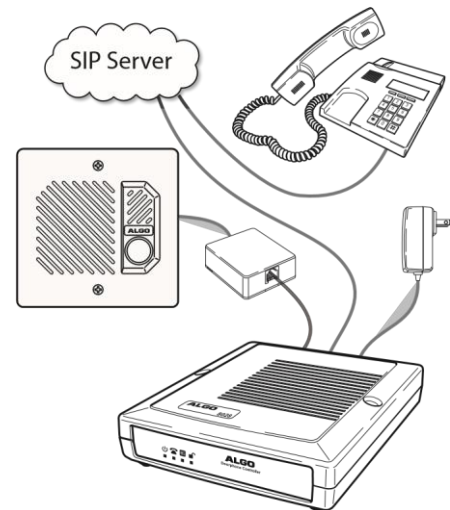

9. Press the call button on the Door Station, then answer to communicate with the Door Station. Press the digit 6 on the phone keypad to activate the door control relay for three seconds (if applicable).

Applications

Typical Applications for Auxiliary Inputs and Outputs

The 8028 architecture and digital link between the Door Station and Controller provides flexible options using the auxiliary inputs and outputs. These are some typical applications.

Cancel Ring When Door Opened

In a residential or warehouse installation it is not uncommon for the door to be answered in person before the phone is answered. Either Door Station or Control Unit inputs can be configured to cancel ring if the door is opened before a call is answered. This requires a normally closed or normally open contact to detect door open.

Trigger Door Bell from Door Station

When the Door Station call button is pressed, either (or both) the Door Station or Control Unit dry contact output can be configured to activate a door bell or auxiliary alerting system in addition to phone ring.

Trigger Door Station from External Button/Event

Either the Control Unit or Door Station can accept a dry contact closure to activate the Doorphone as if the call button had been pressed. This could be an external doorbell button, PIR detector, or some other system.

Cancel Door Open Relay once Door Opened

The door opening control can be set for activation (using the 'Open Code') up to 30 seconds (set by the 'Relay Time' setting) to allow sufficient time for entry. For security, the 8028 Doorphone can be configured to cancel Door Opening once the door is opened to prevent "tailgating" by unauthorized personnel.

Unlock Door Indefinitely until Canceled

The door opening control can be set to unlock indefinitely (using the 'Latch Open Code') until canceled (using the 'Release Code') that locks it again. This allows an entrance to be used repeatedly for a period of time without requiring multiple activations of the door control relay.

Anti-Door Tamper

A feature of the 8028 Doorphone is to ring the telephone(s) with a warning alert in the event a door is ajar due to tampering (such as a door blocked open after being legitimately released for a visitor).

In-User and Ring

Either the Control Unit or Door Station can be configured to provide a dry contact output during ring or in-use for channel selection (typically) of third party video monitoring systems.

Installation

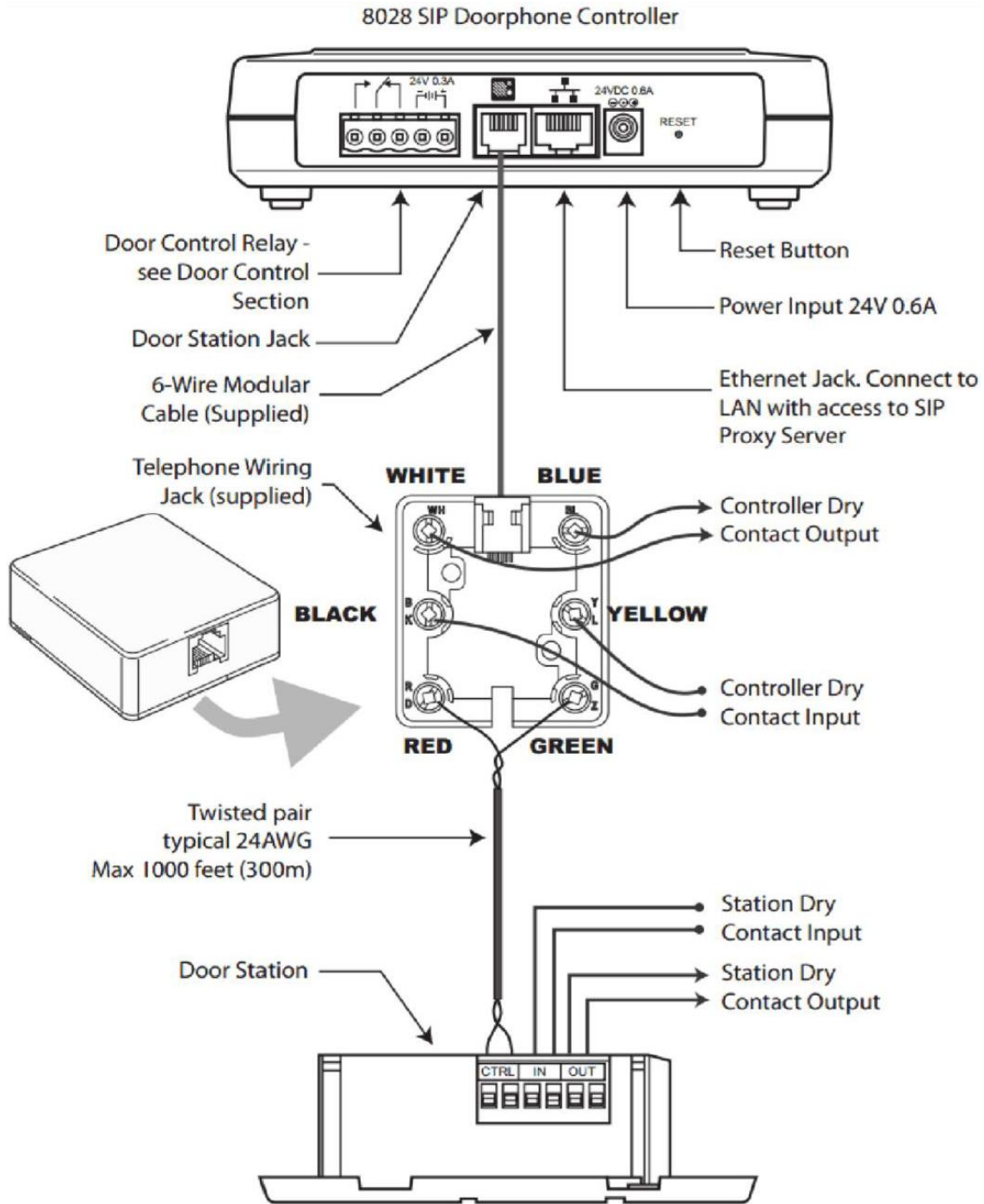

Door Station Installation

The Door Station, provided with the 8028 Doorphone kit, is weather protected for outdoor installation. However if network cabling extends beyond the perimeter of the building then adequate lightning protection is required to protect the cabling and network switch from lightning surges. No lightning protection is required by UL or CSA if the Door Station is located on the outside wall of a building and the wiring is inside the perimeter of the building.

1. Remove the Door Station faceplate
2. Determine if you want a flush or surface mount installation

For surface mount:

- Discard the smaller flush mount gasket.
- Verify the correct orientation of the surface mount gasket.
- Thread the wires through the center hole, then through the surface mount bracket.
- Fasten the surface mount bracket at the desired location on the wall

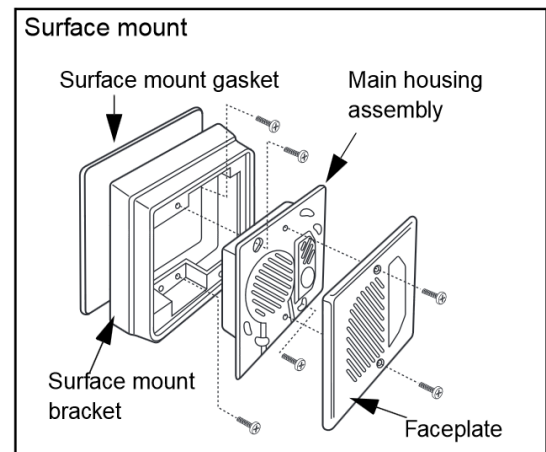

For flush mount:
(Using a dual gang electrical box embedded in the wall)

- Discard the larger surface mount gasket and bracket.
- Slide the flush mount gasket onto the main housing assembly.

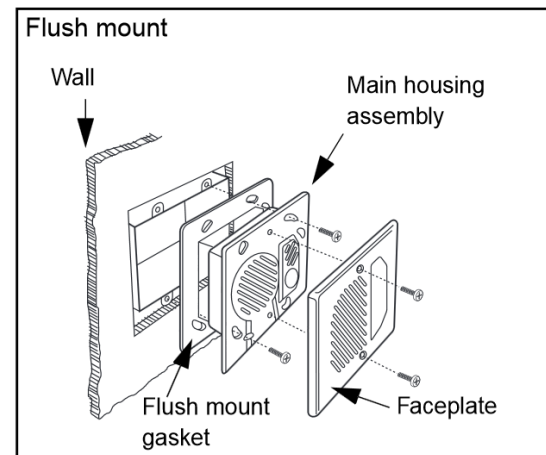

Door or Gate Control Basics

Control contacts are provided from the Doorphone Controller and are typically used for door strike activation or gate control. For security, the door control relay is located in the Controller to avoid entry by tampering.

Door Release

Door release typically involves energizing or de-energizing a door strike which pivots to allow a locked door to open without retraction of the latch bolt. There are two different types of door strikes:

- "Fail Locked" (or "Fail Secure")
- "Fail Unlocked" (or "Fail Safe")

Fail Locked / Fail Secure Electric Strike

These require power to release and remain locked during power failure. The door may still normally be opened from the outside with a key, or from inside without a key. The door control relay is used to apply power to release the door.

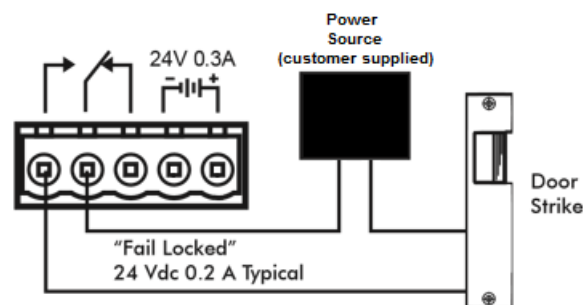

Fail Unlocked / Fail Safe Electric Strike

These (as well as magnetic locks), require power to lock and become unlocked during power failure. The door control relay is used to maintain power to the door lock (NC and C contacts) which is interrupted to release the door. Magnetic locks may require override systems to allow safety exit in the event of fire.

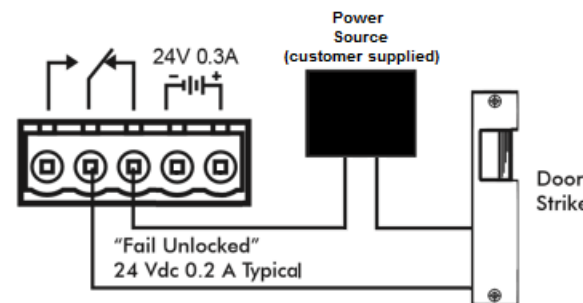

Power Supply

The Doorphone Controller provides an auxiliary 24 V 0.3 A power supply which is suitable for common types of door strikes. If more current or a different voltage is required, then the customer must provide a matching power supply for the electric strike or magnetic lock. Maximum switching capability of the 8028 door control contacts is 1 A 30 V.

The Door Control relay may also be configured for alternate functionality including In-Use, Ring, and Call Button Press.

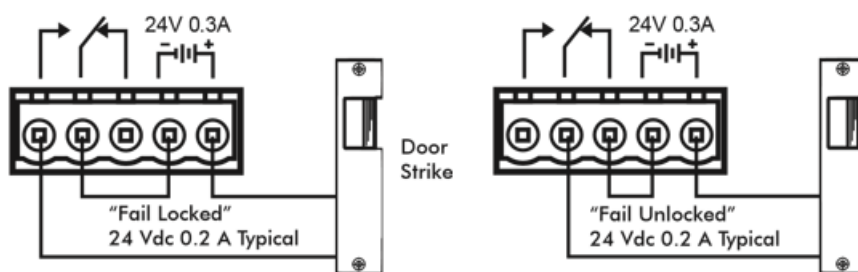



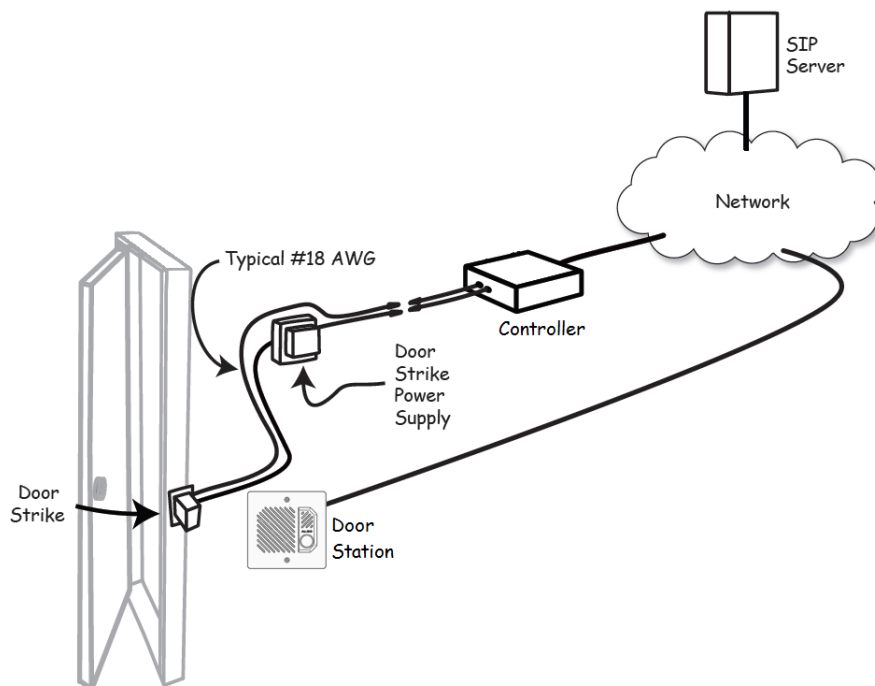

Pre-Wiring Instructions

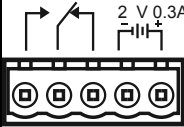

Please visit www.algosolutions.com/doorstrike for more information.

Wiring Connections

Door Control 5 Position Removable Terminal Block	Relay	NO	Normally Open	
		C	Common	
		NC	Normally Closer	
	Optional Auxiliary Power	PWR -	0.3A (GND)	
		PWR +	0.3A (24V)	
Door Station Jack RJ12 Telephone Jack	Center Pair (Red & Green)		Door Station	
	Second Pair (Yellow & Black)		Dry Contract Input Max 1kOhm	
	Outside Pair (Blue & White)		Dry Contract Output Max 50mA 30V	
Ethernet Jack RJ45 Jack	Connect to LAN with access to SIP-compliant Proxy Server.			
Reset Button	To return all settings to a factory default, press and hold the reset button at start up. Continue to hold the button until all LEDs start to flash.			RESET 
Door Station 6 Position Terminal Block	CTRL	Connect to Door Station Jack of Doorphone Controller		
	IN	Dry Contact Input to Door Station (e.g. Door Contact, Doorbell Switch); Max 1kOhm		
	OUT	Dry Contract Output from Door Station (e.g. Gate Control); Max 50mA 30V		

Auxiliary Dry Contact Outputs

Both the Doorphone Controller and Door Station provide a dry contact output for connection to auxiliary devices. Maximum switching capacity is 30 V 50 mA.

This output contains an internal opto-coupler, not a true relay, so it will incur a voltage drop of about 2V.

Default operations are as follows:

- Doorphone Controller Output = In-Use (commonly used for camera control)
- Door Station Output = Call Button Press (commonly used to activate a secondary doorbell)

Other options for Doorphone Controller output include Ring and Call Button Press. Other options for Door Station output include In-Use and Door Control.

Auxiliary Dry Contact Inputs

Both the Doorphone Controller and Door Station can detect a dry contact closure from auxiliary devices. A non-capacitive and non-inductive low voltage and low current is used to detect contact closure.

Default operations are as follows:

- Doorphone Controller input = Door Sensor Normally Closed (used to detect door open)
- Door Station input = Call Button Normally Open (used to detect external doorbell switch)

Options for Doorphone Controller input include Door Sensor Normally Closed, Door Sensor Normally Open, Manual Door Release, Door Control Lockout, Call Button Normally Closed, and Call Button Normally Open.

Options for Door Station input include Door Sensor Normally Closed, Door Sensor Normally Open, Call Button Normally Closed, and Call Button Normally Open.

Red LED Indicators



Power

On steady: Power is OK, but Ethernet Link not established

Blinks one second on, one second off: Ethernet Link status OK, but IP Address not yet obtained

Light on, blinks off briefly every two seconds: Link and IP Address established successfully



Telephone

Off: Not registered with SIP server

Light on, blinks off briefly every two seconds: Successfully registered with SIP Server, ready for use

Blinks one second on, one second off: error registering with SIP Server – check configuration

On steady: off-hook or ringing state is currently active



Door Station

On steady: the door station is connected

Flashing: Communication errors with the door station



Unlock

On steady: Door Relay is activated.

Testing the door control feature: the “unlock” light on the 8028 will turn on (and the mechanical relay may be heard) when the Open Code is pressed from the telephone keypad during a call with the 8028 intercom. This light shows the state of the relay, and verifies that it has activated. If the “unlock” light activates, but the door fails to unlock, please contact your electrician to check the connections and wiring to the door strike. If the “unlock” light does not turn on, verify that the phone sends a DTMF signal to the Doorphone.

Web Interface

The 8028 SIP Doorphone is configurable using the web interface or provisioning features.

After boot up the red call button will turn on and the Doorphone will have obtained an IP address. If there is no DHCP server the 8028 SIP Doorphone will default to the static IP address **192.168.1.111**.

Before the 8028 is configured, the call button on the Door Station can be pressed to play the IP address over the speaker. (Once the SIP Server field is populated on the 8028 web interface, the call button will contact the preconfigured extension when pressed.) The IP address may also be discovered by downloading the Algo locator tool to find Algo devices on your network: www.algosolutions.com/locator

Enter the IP address (eg 192.168.1.111) into a browser such as Google Chrome, Firefox, or Internet Explorer (other than IE9). The web interface should be visible and the default password will be **algo** in lower case letters.

Web Interface Login

The web interface requires a password which is "**algo**" by default. This password can be changed using the *Admin* tab after logging in the first time.

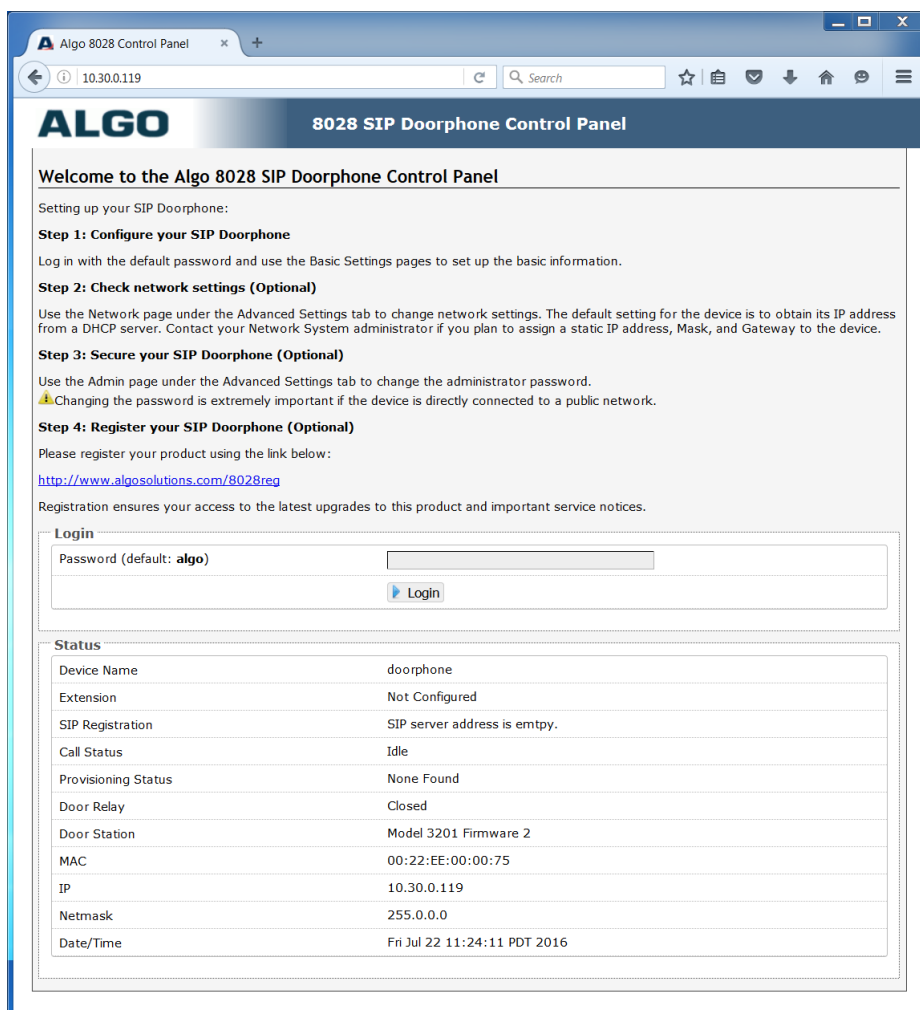

Status

The device's Status page will be available before and after log on. The section can be used to check 8028's SIP Registration status of the Ring/Page extensions, Call Status, Relay Input Status, Proxy Status, and general MAC, IP, Netmask, Date/Time, and Timezone information.

Refresh the page to see the latest status.

Basic Settings Tab – SIP

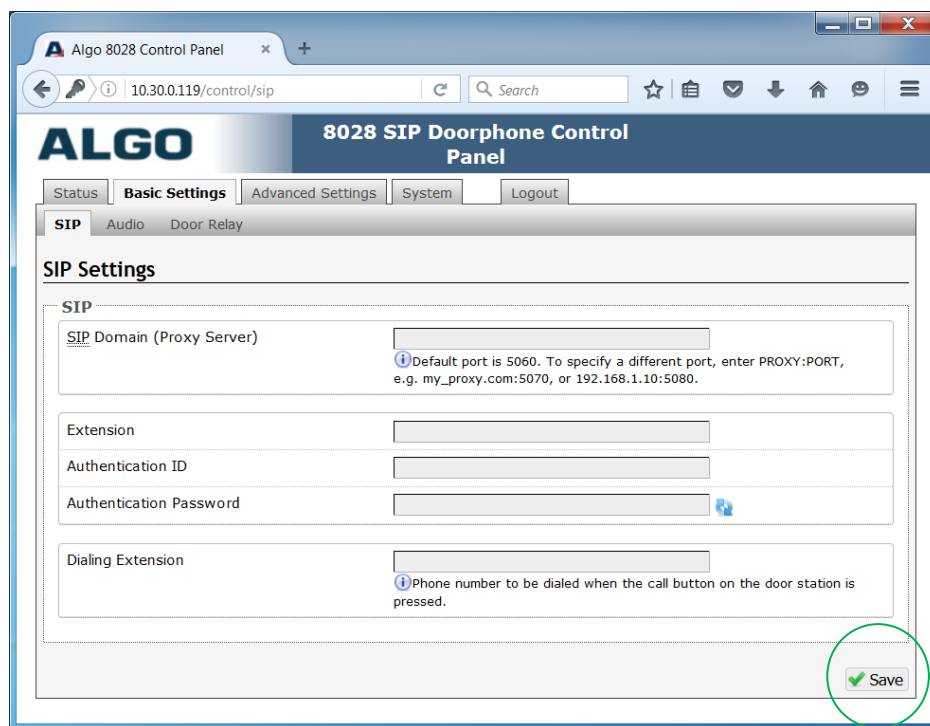

Note: Any time changes are made to settings in the Web Interface the "Save" key must be clicked to save the changes

SIP Domain (Proxy Server)

SIP Server Name or IP Address

Extension

The phone number that the 8028 registers with the SIP Server. It will auto-answer any inbound calls.

Authentication ID

ID used to register the device on the SIP Server. May also be called Username for some SIP servers and in some cases may be the same as the SIP extension.

Authentication Password

SIP password provided by the system administrator for the SIP account.

Dialing Extensions

Phone number to be dialed when the Call button on the door station is pressed. This can also be a Hunt Group number. Ensure that voice mail is not reached.

Basic Settings Tab - Audio

The screenshot shows the ALGO web interface. At the top, there are navigation tabs: Status, Basic Settings, Advanced Settings, System, and Logout. Below these, there are sub-tabs for SIP, Audio, and Door Relay. The Audio Settings section is active and contains the following settings:

Audio Settings	
Speaker Volume	8 <input type="button" value="Apply"/>
Microphone Volume	7 <input type="button" value="Apply"/>
Ringback Tone	<input checked="" type="radio"/> Enabled <input type="radio"/> Disabled

At the bottom right of the settings area, there is a button.

Speaker Volume

Doorphone speaker audio level from 1 (lowest) to 10 (highest).

Microphone Volume

Microphone audio level from 1 (lowest) to 10 (highest).

Ringback Tone

Allow audible ringback tone to be played on the doorphone speaker until the call is answered.

Basic Settings Tab – Door Relay

The screenshot displays the 'Door Relay Settings' configuration page. At the top, there are navigation tabs: Status, Basic Settings (selected), Advanced Settings, System, and Logout. Below these are sub-tabs: SIP, Audio, and Door Relay. The main content area is titled 'Door Relay Settings' and contains the following fields:

- Momentary Open Code:** A text input field containing the number '6'. A tooltip below it indicates 'Max 4 digits'.
- Duration:** A dropdown menu set to '3 seconds'.
- Cancel if Door Opened:** Radio buttons for 'Yes' and 'No', with 'No' selected.
- Latch Open Code:** An empty text input field with a 'Max 4 digits' tooltip.
- Latch Closed Code:** An empty text input field with a 'Max 4 digits' tooltip.
- DTMF Detection Type:** Radio buttons for 'Auto' (selected), 'RTP Out-of-band (RFC 2833)', 'RTP In-band', and 'SIP INFO'.
- Door Unlock Tone:** Radio buttons for 'Enabled' and 'Disabled', with 'Disabled' selected.
- Allow Network Control:** Radio buttons for 'Yes' and 'No', with 'No' selected. A tooltip below it reads: 'Allow auxiliary relay control by network command. Contact support for more information.'

A green 'Save' button is located at the bottom right of the settings area.

Momentary Open Code

1-4 digit DTMF code that can be used to unlock the door for a brief period of time. Leave this field blank to disable this feature. (Default: 6)

Duration

The time period for which to unlock the door when the Momentary Open Code is entered. From ¼ to 30 seconds.

Cancel if Door Opened

Cancels the door unlock (i.e. locks the door again) if the door has been opened to ensure it cannot be opened a 2nd time. Only available if the controller input or door station input is configured for Door Sensor mode.

Physical Door Sensor is required at the door (not included).

Latch Open Code

1-4 digit DTMF code that can be used to unlock the door indefinitely. Leave this field blank to disable this feature.

Latch Closed Code

1-4 digit DTMF code that will lock the door again when it is latched open. Leave this field blank to disable this feature.

DTMF Detection Type

Use the default of 'Auto' unless advised by Algo technical support.

Door Unlock Tone

A sound can be played when a door is unlocked, to create awareness.

Allow Network Control

Allow auxiliary relay control by network command. Contact support for more information.

Advanced Settings Tab - Network

Protocol

DHCP is an IP standard designed to make administration of IP addresses simpler. When selected, DHCP will automatically configure IP addresses for each 8028 SIP Doorphone on the network. Alternatively the 8028 can be set to a static IP address.

VLAN Mode

Enables or Disables VLAN Tagging. VLAN Tagging is the networking standard that supports Virtual LANs (VLANs) on an Ethernet network. The standard defines a system of VLAN tagging for Ethernet frames and the accompanying procedures to be used by bridges and switches in handling such frames. The standard also provides provisions for a quality of service prioritization scheme commonly known as IEEE 802.1p and defines the Generic Attribute Registration Protocol.

VLAN ID

Specifies the VLAN to which the Ethernet frame belongs. A 12-bit field specifying the VLAN to which the Ethernet frame belongs. The hexadecimal values of 0x000 and 0xFFF are reserved. All other values may be used as VLAN identifiers, allowing up to 4094 VLANs. The reserved value 0x000 indicates that the frame does not belong to any VLAN; in this case, the 802.1Q tag specifies only a priority and is referred to as a priority tag. On bridges, VLAN 1 (the default VLAN ID) is often reserved for a management VLAN; this is vendor specific.

VLAN Priority

Sets the frame priority level. Otherwise known as Priority Code Point (PCP), VLAN Priority is a 3-bit field which refers to the IEEE 802.1p priority. It indicates the frame priority level. Values are from 0 (lowest) to 7 (highest).

Differentiated Services (6-bit DSCP value)

Provides quality of service if the DSCP protocol is supported on your network. Can be specified independently for SIP control packets versus RTP audio packets.

Advanced Settings Tab – Admin

The screenshot shows the 'Advanced Settings' tab with the 'Admin' sub-tab selected. The interface includes the following sections:

- Admin Password:** Fields for 'Password' and 'Confirmation', both currently showing masked characters (dots).
- General:**
 - 'Device Name (Hostname)': Text field containing 'doorphone'.
 - 'Introduction Section on Status Page': Radio buttons for 'On' (selected) and 'Off'.
 - 'Web Interface Session Timeout': Dropdown menu set to '1 hour', with a note: 'Web interface can log out after period of inactivity.'
- Log Settings:**
 - 'Log Level': Radio buttons for 'Error (Lowest)', 'Notice ("Event")', 'Info ("SIP")' (selected), and 'Debug (Highest)'.
 - 'Log Size (1 ~ 1000 kB)': Text field containing '100'.
 - 'Log Method': Radio buttons for 'Local' (selected), 'Network', and 'Both'.
- High Availability:**
 - 'Hardware Watchdog': Radio buttons for 'Enabled' and 'Disabled' (selected).
- Management:**
 - 'SNMP Support (v1 get only)': Radio buttons for 'Enabled' and 'Disabled' (selected).

A green 'Save' button is located at the bottom right of the settings area.

Password

Password to log into the 8028 SIP Doorphone web interface. You should change the default password **algo** in order to secure the device on the network. If you have forgotten your password, you will need to perform a reset using the Reset Button in order to restore the password (as well as all other settings) back to the original factory default conditions.

Confirmation

Re-enter network admin password.

Device Name

Name to identify the device in the Algo Network Device Locator Tool.

Introduction Section on Status Page

Allows the introduction text to be hidden from the login screen.

Web Interface Session Timeout

Set the maximum period of inactivity after which the web interface will log out automatically.

Log Level

Use on the advice of Algo technical support only.

Log Size

Consult Algo technical support.

Log Method

Allows the 8028 SIP Doorphone to write to external Syslog server if the option for external (or both) is selected.

Log Server

If external (or both) is selected this is the address of the Syslog server on the network.

Hardware Watchdog

Use on the advice of Algo technical support only.

SNMP Support (v1 get only)

Additional SNMP support is anticipated for future, but the 8028 SIP Doorphone will respond to a simple status query for automated supervision. Contact Algo technical support for more information.

Advanced Settings Tab – Time

The screenshot shows the 'Advanced Settings' tab for the 'Time' section. The page has a navigation bar with tabs for 'Status', 'Basic Settings', 'Advanced Settings', 'System', and 'Logout'. Below this is a sub-navigation bar with tabs for 'Network', 'Admin', 'Time', 'Provisioning', 'Call', 'Auxiliary I/O', 'Security', and 'Advanced SIP'. The 'Time Settings' section is titled and contains a 'General' sub-section with two fields: 'Timezone' set to '(UTC-08:00) Pacific Time (US and Canada)' and 'NTP Time Server' set to 'pool.ntp.org'. A 'Save' button with a green checkmark is located at the bottom right of the form.

Network time is used for logging events into memory for troubleshooting.

Time Zone

Select time zone.

NTP Time Server

Allows the 8028 to synchronize to an external time server.

Advanced Settings Tab – Provisioning

Note: It is recommended that Provisioning Mode be set to Disabled if this feature is not in use. This will prevent unauthorized re-configuration of the device if DHCP is used.

Provisioning allows installers to pre-configure 8028 SIP Doorphone units prior to installation on a network. It is typically used for large deployments to save time and ensure consistent setups.

There are two different Provisioning methods that can be used: via DHCP Option 66 or via a Static Server. In addition, there are three different ways to download provisioning files from a "Provisioning Server": TFTP (Trivial File Transfer Protocol), FTP, or HTTP.

For example, 8028 SIP Doorphone configuration files can be automatically downloaded from a TFTP server using DHCP Option 66. This option code (when set) supplies a TFTP boot server address to the DHCP client to boot from.

DHCP must be enabled if using DHCP Option 66, in order for Provisioning to work.

One of two files can be uploaded on the Provisioning Server (for access via TFTP, FTP, or HTTP):

Generic (for all Algo 8028 Doorphone)	algop8028.conf
Specific (for a specific MAC address)	algom[MAC].conf

MD5 Checksum

In addition to the .conf file, an .md5 checksum file must also be uploaded to the Provisioning server. This checksum file is used to verify that the .conf file is transferred correctly without error.

A tool such as can be found at the website address below may be used to generate this file:

<http://www.fourmilab.ch/md5>

The application doesn't need an installation. To use the tool, simply unzip and run the application (md5) from a command prompt. The proper .md5 file will be generated in the same directory.

If using the above tool, be sure to use the "-l" parameter to generate lower case letters.

Generating a generic configuration file

1. Connect 8028 to the network
2. Access the 8028 Web Interface Control Panel
3. Configure the 8028 with desired options
4. Click on the System tab and then Maintenance.
5. Click "Backup" to download the current configuration file
6. Save the file settings.txt
7. Rename file settings.txt to algop8028.conf
8. File algop8028.conf can now be uploaded onto the Provisioning server

If using a generic configuration file, extensions and credentials have to be entered manually once the 8028 SIP Doorphone has automatically downloaded the configuration file.

Generating a specific configuration file

1. Follow steps 1 to 6 as listed in the section "Generating a generic configuration file".
2. Rename file settings.txt to algom[MAC address].conf (e.g. algom0022EE020009.conf)
3. File algom[MAC address].conf can now be uploaded on the Provisioning server.

The specific configuration file will only be downloaded by the 8028 SIP Doorphone with the MAC address specified in the configuration file name. Since all the necessary settings can be included in this file, the 8028 will be ready to work immediately after the configuration file is downloaded. The MAC address of each 8028 SIP Doorphone can be found on the back label of the unit.

For more Algo SIP endpoint provisioning information, see:
www.algosolutions.com/provision

Advanced Settings Tab – Call

The screenshot shows the 'Call Settings' configuration page in the ALGO web interface. The page is divided into three sections:

- General:**
 - Answer Inbound Call: Enabled Disabled
 - Answer Tone: Enabled Disabled
- Outbound Call:**
 - Outbound Ring Limit: 5 rings (1 ring = 6 seconds)
 - Cancel if Door Opened: Yes No
 - Allow Call Button to End Outbound Call: Enabled Disabled
- General:**
 - Maximum Call Duration: None

A 'Save' button is located at the bottom right of the page.

Answer Inbound Call

Allow the 8028 to auto answer an inbound call. By default, this functionality is activated.

Answer Tone

An optional beep tone can be played over the speaker when the Door Station answers an inbound call.

Outbound Ring Limit

Typically set to ensure that a call will not reach voicemail. This feature can be used to set a limit on how long the speaker will ring before timing out.

Cancel if Door Opened

Cancel dial attempt if door has been opened before call is answered. Only available if the controller input or door station input is configured for Door Sensor mode, and a physical sensor (not included) is available at the door.

Allow Call Button to End Outbound Call

If enabled, allows the visitor to end an active call by pressing the call button.

Maximum Call Duration

Select the maximum call length. The call will be terminated once the maximum time is reached. In the event that a call inadvertently reaches voicemail or gets accidentally left on hold, this setting ensures that the 8028 returns on-hook.

Advanced Settings Tab – Auxiliary I/O

The screenshot shows the 'Advanced Settings' tab for 'Auxiliary I/O'. The page is titled 'Auxiliary Input/Output Settings'. It is divided into two main sections: 'Output' and 'Input'.
Output Section:
 - Controller Output: In-Use
 - Door Station Output: Call Button Press
 - Door Relay: Door Control
 - In-Use Definition: Call Connected, Call Ringing or Connected
Input Section:
 - Controller Input: Door Sensor, Normally Closed Input
 - Door Station Input: Call Button, Normally Open Input
 A 'Save' button is located at the bottom right of the form.

Controller Output

Output can be configured to trigger one of the following controller events:

- In-Use (Default)
- Ring
- Call Button Press
- Door Control
- Door Sensor
- Door Alarm
- Follow Controller Input
- Follow Station Input
- Disabled

Door Station Output

Output can be configured to trigger one of the following Door Station events:

- In-Use
- Ring
- Call Button Press (Default)
- Door Control
- Door Sensor
- Door Alarm
- Follow Controller Input
- Follow Station Input
- Disabled

Door Relay

Door Relay can be configured to trigger one of the following events:

- In-Use
- Ring
- Call Button Press
- Door Control (Default)
- Door Sensor
- Door Alarm
- Follow Controller Input
- Follow Station Input
- Disable

In-Use Definition

Select the meaning of the "In-Use" status to be either "Call Connected" or "Call Ringing or Connected."

Controller Input

Select input type to the Controller:

- Door Sensor, Normally Open Input
- Door Sensor, Normally Closed Input (Default)
- Manual Door Release Input
- Door Control Lockout Input
- Call Button, Normally Open Input
- Call Button, Normally Closed Input
- Disabled

Door Station Input

Select input type to the Door Station:

- Door Sensor, Normally Open Input
- Door Sensor, Normally Closed Input
- Call Button, Normally Open Input (Default)
- Call Button, Normally Closed Input
- Disabled

Advanced Settings Tab – Security

Security	
Max Door Open	None
Door Open Alarm	None
Door Station Disconnected	None

Max Door Open

If the Controller or Door Station input is connected to a physical door sensor and also configured in Door Sensor mode (“Advanced Settings > Auxiliary I/O”), then a Door Alarm condition can be triggered if the door remains open for longer than the selected threshold (30 seconds to 120 minutes).

Door Open Alarm

When a Door Alarm condition is detected based on the Max Door Open time above exceeded (2 minutes to None), then the 8028 can generate a notification call.

Door Station Disconnected

If a wiring fault occurs that breaks communication with the Door Station, then the 8028 can generate a notification call at specified time intervals (every 2 minutes to None).

Advanced Settings Tab – Advanced SIP

Outbound Proxy

IP address for outbound proxy. A proxy (server) stands between a private network and the internet.

STUN Server

IP address for STUN server if present.

Register/Subscribe Period (seconds)

Maximum requested period of time where the 8028 SIP Doorphone will re-register with the SIP server. Default setting is 3600 seconds (1 hour). Only change if instructed otherwise.

Keep-alive Method

If Double CRLF is selected the 8028 SIP Doorphone will send a packet every 30 seconds (unless changed) to maintain connection with the SIP Server if behind NAT.

Server Redundancy Feature

Two secondary SIP servers may be configured. The 8028 SIP Doorphone will attempt to register with the primary server but switch to a secondary server when necessary. The configuration allows re-registration to the primary server upon availability or to stay with a server until unresponsive.

If Server Redundancy is selected the web page will expand as shown below.

Backup Server #1

If primary server is unreachable the 8028 will attempt to register with the backup servers. If enabled, the 8028 will always attempt to register with the highest priority server.

Backup Server #2

If backup server #1 is unreachable the 8028 SIP Doorphone will attempt to register with the 2nd backup server. If enabled, the 8028 SIP Doorphone will always attempt to register with the highest priority server.

Polling Intervals (seconds)

Time period between sending monitoring packets to each server. Non-active servers are always polled, and active server may optionally be polled (see below).

Poll Active Server

Explicitly poll current server to monitor availability. May also be handled automatically by other regular events, so can be disabled to reduce network traffic.

Automatic Failback

Reconnect with higher priority server once available, even if backup connection is still fine.

Polling Method

SIP message used to poll servers to monitor availability.

System Tab - Maintenance

The screenshot shows a web interface for system maintenance. At the top, there are navigation tabs: Status, Basic Settings, Advanced Settings, System (selected), and Logout. Below these are sub-tabs: Maintenance (selected), System Log, and About. The main content area is titled "System Maintenance" and is divided into three sections:

- Backup / Restore Configuration:** Contains three rows. The first row has "Download Configuration File" and a "Backup" button. The second row has "Restore Configuration File", a "Browse..." button, "No file selected.", and a "Restore" button. The third row has "Restore Configuration to Defaults" and a "Restore Defaults" button.
- Reboot:** Contains one row with "Reboot the device" and a "Reboot" button.
- Upgrade to New Firmware:** Contains four rows. The first row has "Method" with radio buttons for "From Local Files" (selected) and "From URL". The second row has "Firmware Image", a "Browse..." button, and "No file selected.". The third row has "MD5 Checksum", a "Browse..." button, and "No file selected.". The fourth row has "Upgrade" and an "Upgrade" button.

Download Configuration File

Save the device settings to a text file for backup or to setup a provisioning configuration file.

Restore Configuration File

Restore settings from a backup file.

Restore Configuration to Defaults

Resets all 8028 SIP Doorphone device settings to factory default values.

Reboot the Device

Reboots the device.

Method

Specify whether the firmware files will be downloaded from the local computer or a remote URL.

Firmware Image

Point to the firmware image provided by Algo.

MD5 Checksum

Point to the checksum file provided by Algo.

Upgrade 8028 SIP Doorphone Firmware

1. From the top menu, click on System, then Maintenance.
2. In the Maintenance section, click Reboot, and wait 30-60 seconds for the device to reboot and the web page to automatically reload.
3. Login to the device again, and click on System.
4. In the Upgrade section, click on Choose File and select the 8028 SIP Doorphone firmware file to upload. Note that both the FW firmware and MD5 checksum files must be loaded.
5. Click Upgrade
6. After the upgrade is complete, confirm that the firmware version has changed (refer to top right of Control Panel).

System Tab - Network Logging

System log files are automatically created and assist with troubleshooting in the event the 8028 SIP Doorphone does not behave as expected.

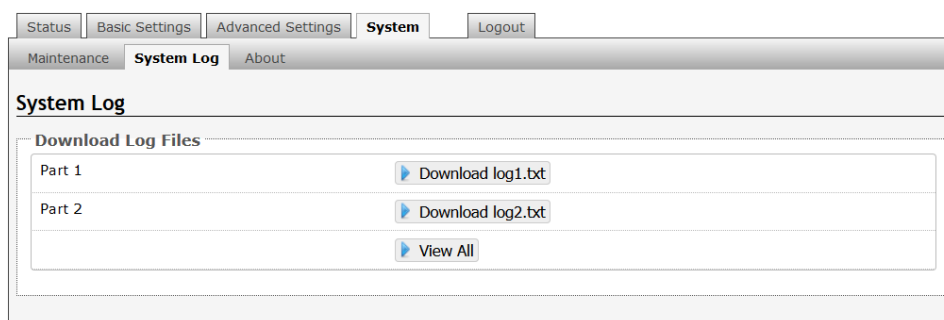

Specifications

Compatibility:	SIP
Configuration:	Web Interface or Auto-Provisioning via TFTP, FTP or HTTP
Network Address:	DHCP or static IP address
NAT*:	STUN Server or Keep-Alive * (Network Address Translation)
Speech:	Full Duplex Capable
Codec:	G.711
Physical:	Separate Controller and Door Station

CONTROLLER

Power:	AC Mains Adapter 95-230V 50/60Hz Included
Dimensions:	5.6" x 6.85" x 1.57" (142mm x 174mm x 40mm)



Indicators:	Power, Door Station Status, In-Use, Door Unlock
Network Connection:	RJ45 Jack
Installation:	Shelf or wall mounted
Environmental:	Dry indoor location

Door Control Connection:	5 Position terminal strip
Door Control Power:	Available 24V, 300mA Strike power +/-
Door Control Relay:	Relay C, NO, NC phone keypad activated; Maximum 30V, 1A
Door Station Connection:	RJ12 Jack Center Pair
Door Station Wiring:	24 AWG Twisted Pair to 1000 Ft (300 m)
Auxiliary Input Connection:	RJ12 Jack Second Pair
Auxiliary Input Electrical:	Detects dry contact closure 24V 4mA sensing current
Auxiliary Input Functions:	Manual door release; Door control lockout; Door sensor NC (Default) or NO; Call button NC or NO; Disabled
Auxiliary Output Connection:	RJ12 Jack Outside Pair
Auxiliary Output Electrical:	Normally open switch 180 Ohms active; Internal opto-coupler, 2V drop; Maximum 30V, 50mA
Auxiliary Output Functions:	In-Use (Default); Ringing; Call button pressed; Door unlock; Door open (requires door sensor); Door alarm (requires door sensor); Door sensor NC (Default) or NO; Follow Controller input; Follow Door Station input; Disabled

DOOR STATION

Power:	Provided by Controller link
Dimensions:	4.5" x 4.5" x 1.18" (115mm x 115mm x 30mm)

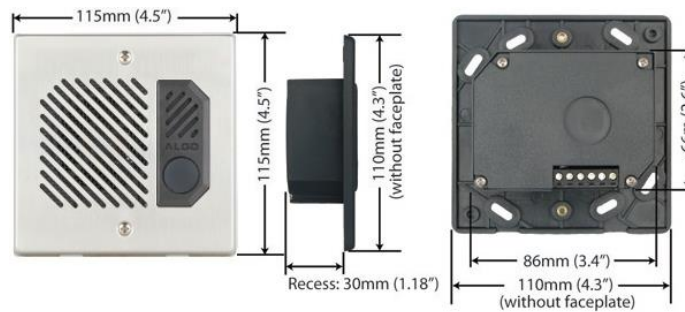

Wiring:	Up to 1000 Ft (300 m) 24 AWG single twisted pair to controller
Signalling:	Digital link - bi-directional voice and data
Call Button Connections:	Backlit tactile silicon rubber 6 Position terminal strip - Controller, Aux In, Aux Out
Installation:	Flush or surface mounted using supplied plastic bezel; Fits two gang electrical box
Environmental:	NEMA 3R Rated for outdoor locations; Ambient temperature -30 to +60° C.
Auxiliary Input Functions:	Door sensor NC or NO; Call button NC or NO (Default); Disabled
Auxiliary Input Electrical:	Detects dry contact closure 5 V, 1 mA sensing current
Auxiliary Output Functions:	In-Use; Ringing; Call button pressed (Default) Door/gate unlock; Door open (requires door sensor); Door alarm (requires door sensor); Door sensor NC (Default) or NO; Follow Controller input; Follow Door Station input; Disabled
Auxiliary Output Electrical:	Normally open switch 180Ohms active; Internal opto-coupler, 2V drop; Maximum 30V, 50mA

FCC Compliance Statement

This equipment has been tested and found to comply with the limits for a Class B digital device, pursuant to part 15 of the FCC Rules. These limits are designed to provide reasonable protection against harmful interference in a residential installation. This equipment generates, uses and can radiate radio frequency energy and, if not installed and used in accordance with the instructions, may cause harmful interference to radio communications. However, there is no guarantee that interference will not occur in a particular installation. If this equipment does cause harmful interference to radio or television reception, which can be determined by turning the equipment off and on, the user is encouraged to try to correct the interference by one or more of the following measures:

- Reorient or relocate the receiving antenna.
- Increase the separation between the equipment and receiver.
- Connect the equipment into an outlet on a circuit different from that to which the receiver is connected.
- Consult the dealer or an experienced radio/TV technician for help.